

THIS DRAWING IS UNPUBLISHED. RELEASED FOR PUBLICATION
 © COPYRIGHT BY TYCO ELECTRONICS CORPORATION. ALL RIGHTS RESERVED.

LOC	DIST	REVISIONS			
P	LTR	DESCRIPTION	DATE	DWN	APVD
FT	0	F1	REVISED PER ECO-06-21627	9/13/06	SS GS

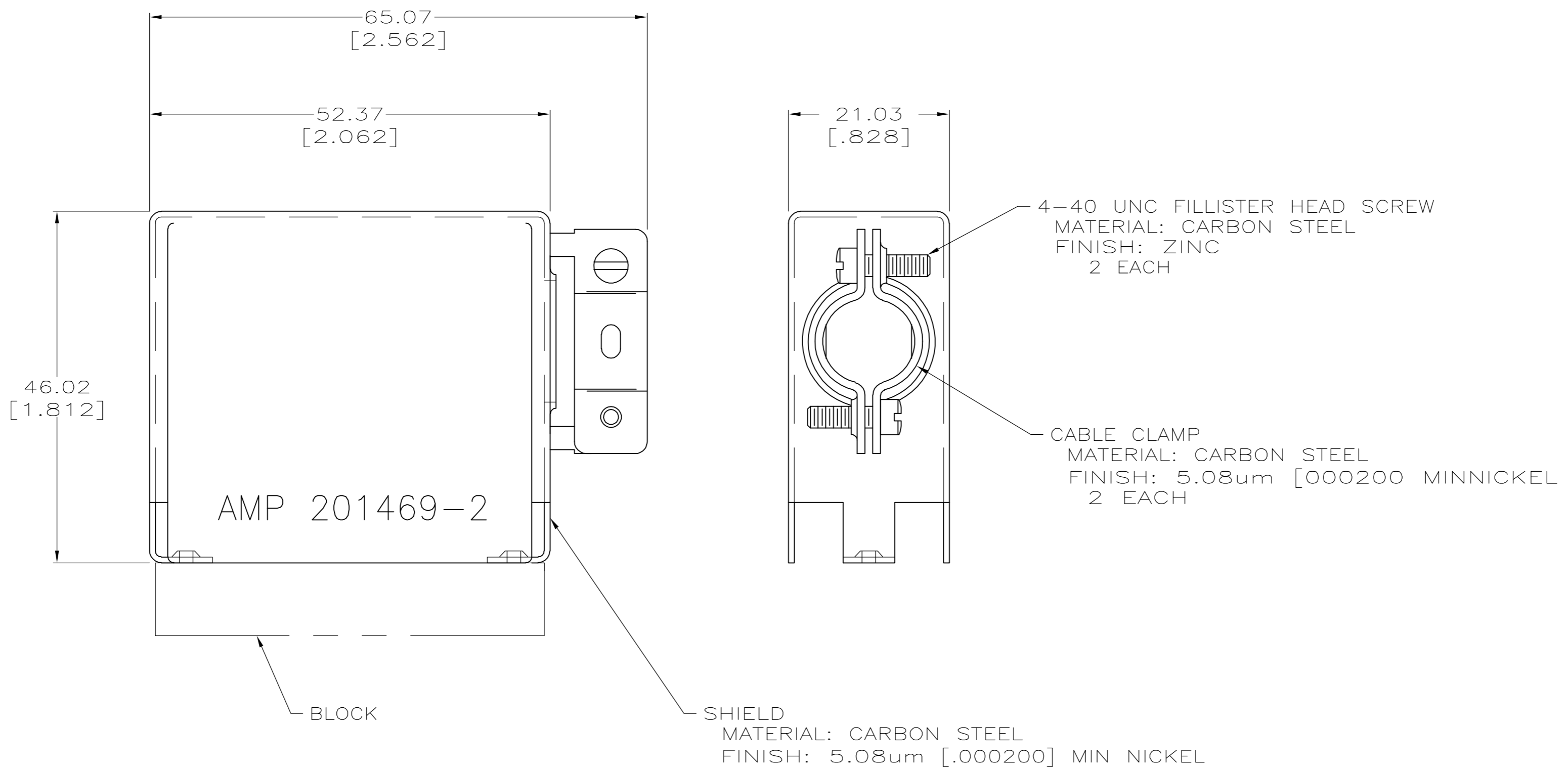

ASSEMBLED VIEW

3	201469-3
2	201469-2
SCREW FINISH	PART NUMBER

- CABLE CLAMP WILL ACCEPT 34 WIRES OF 1.78 [.070] MAX DIA.
- FINISH: ZINC WITH HEXAVALENT CHROMATE.
- FINISH: ZINC WITH NON-HEVALENT CHROMATE.

THIS DRAWING IS A CONTROLLED DOCUMENT.		DWN	C.DORWART	07 NOV 95	Tyco Electronics Corporation Harrisburg, PA 17105-3608							
DIMENSIONS: mm [INCHES]		CHK	R.STONE	15 DEC 95								
TOLERANCES UNLESS OTHERWISE SPECIFIED:		APVD	G.STEINHAUER	18 JAN 96								
0 PLC ± - 1 PLC ± - 2 PLC ± 0.38 [.015] 3 PLC ± - 4 PLC ± - ANGLES ± - FINISH -		PRODUCT SPEC	NAME			SHIELD KIT, UNASSEMBLED, SHORT, 34 POSITION, M SERIES						
MATERIAL	-	APPLICATION SPEC	-		SIZE	A2	CAGE CODE	00779	DRAWING NO	C=201469	RESTRICTED TO	-
CUSTOMER DRAWING		WEIGHT	-		SCALE	2:1		SHEET	1 of 1		REV	F1